

Features

- Sensitive Layer Over a 0.8 μm CMOS Array
- Image Zone: 0.4 x 14 mm = 0.02" x 0.55"
- Image Array: 8 x 280 = 2240 pixels
- Pixel Pitch: 50 μm x 50 μm = 500 dpi
- Pixel Clock: up to 2 MHz Enabling up to 1780 Frames per Second
- Die Size: 1.7 x 17.3 mm
- Operating Voltage: 3V to 5.5V
- Naturally Protected Against ESD: > 16 kV Air Discharge
- Power Consumption: 20 mW at 3.3V, 1 MHz, 25°C
- Operating Temperature Range:
 - 0°C to +70°C: C suffix
 - -20°C to +70°C: D suffix
 - -40°C to +85°C: I suffix
- Resistant to Abrasion: >1 Million Finger Sweeps
- Chip-On-Board (COB), Chip-On-Board (COB) with Connector, or 20-lead Ceramic DIP Available for Development, with Specific Protective Layer

Applications

- PDA (Access Control, Data Protection)
- Cellular Phones, SmartPhone (Access e-business)
- Notebook, PC-add on (Access Control, e-business)
- PIN Code Replacement
- Automated Teller Machine, POS
- Building Access
- Electronic Keys (Cars, Home,...)
- Portable Fingerprint Imaging for Law Enforcement
- TV Access

Figure 1. FingerChip™ Packages

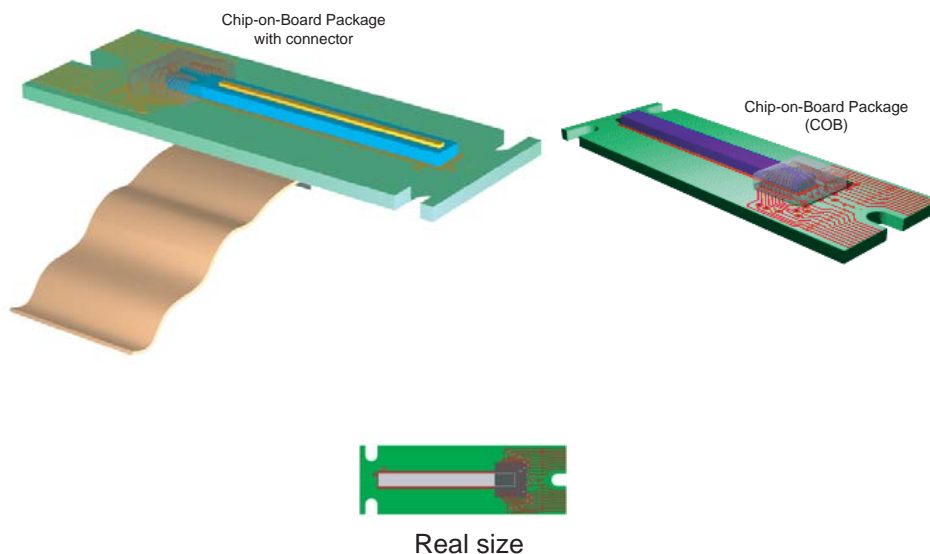

Note: AT77C101B part number replaces FCD4B14 and refers to same sensor.



**Thermal
Fingerprint
Sensor with
0.4 mm x 14 mm
(0.02" x 0.55")
Sensing Area
and
Digital Output
(On-chip ADC)**

**AT77C101B
FingerChip™
Preliminary**



Rev. 2150B-BIOM-04/03



Table 1. Pin Description for Chip-On-Board Package: AT77C101B-CB01Θ

Pin Number	Name	Type
1	GND	GND
2	AVE	Analog output
3	AVO	Analog output
4	TPP	Power
5	TPE	Digital input
6	VCC	Power
7	GND	GND
8	RST	Digital input
9	PCLK	Digital input
10	OE	Digital input
11	ACKN	Digital output
12	De0	Digital output
13	Do0	Digital output
14	De1	Digital output
15	Do1	Digital output
16	De2	Digital output
17	Do2	Digital output
18	De3	Digital output
19	Do3	Digital output
20	FPL	GND
21	GND	GND

Die Attach is connected to pins 1, 7 and 21, and must be grounded. FPL pin must be grounded.

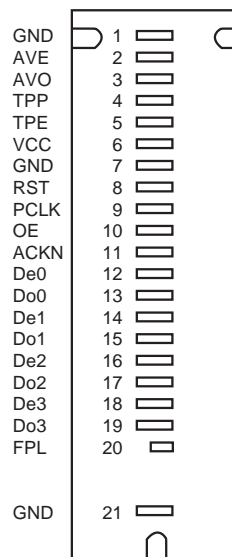

Table 2. Pin Description for COB with Connector Package: AT77C101B-CB02 Θ ⁽¹⁾

Pin Number	Name	Type
1	FPL	GND
2	Not connected	
3	Not connected	
4	DE3	Digital output
5	DO3	Digital output
6	DE2	Digital output
7	DO2	Digital output
8	DE1	Digital output
9	DO1	Digital output
10	DE0	Digital output
11	DO0	Digital output
12	AVE	Analog output
13	AVO	Analog output
14	TPP	Power
15	TPE	Digital input
16	VCC	Power
17	GND	GND
18	RST	Digital input
19	PCLK	Digital input
20	OE	Digital input
21	ACKN	Digital output

Note: 1. "Ref Connector: FH18-21S-0.3SHW (HiROSE)" on page 4

Figure 2. COB with Flex⁽²⁾

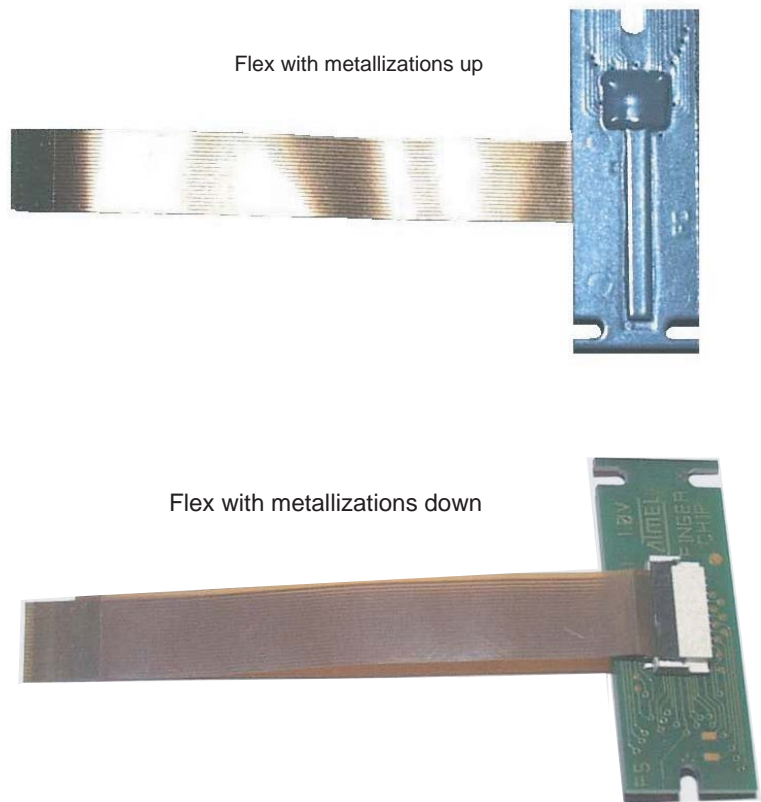
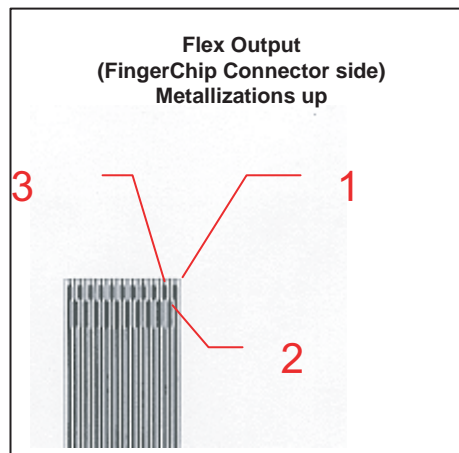

Figure 3. Flex Output Side



- Notes: 1. Ref Connector: FH18-21S-0.3SHW (HiROSE)
2. Flex is not provided by ATMEL

Table 3. Pin Description For DIP Ceramic Package: FCD4B14C0

Pin Number	Name	Type
1	GND	GND
2	AVE	Analog output
3	TPP	Power
4	VCC	Power
5	RST	Digital input
6	OE	Digital input
7	De0	Digital output
8	De1	Digital output
9	De2	Digital output
10	De3	Digital output
11	FPL	GND
12	Do3	Digital output
13	Do2	Digital output
14	Do1	Digital output
15	Do0	Digital output
16	GND	GND
17	ACKN	Digital output
18	PCLK	Digital input
19	TPE	Digital input
20	AVO	Analog output

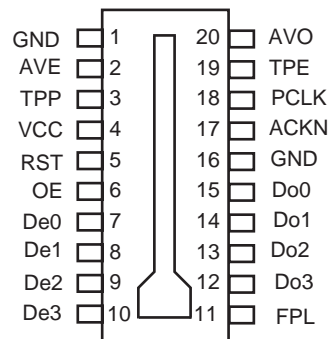

Die Attach is connected to pins 1 and 16, and must be grounded. FPL pin must be grounded.

Description

AT77C101B is part of the Atmel FingerChip monolithic fingerprint sensor family for which, no optics, no prism and no light source are required.

AT77C101B is a single chip, high performance, low cost sensor based on temperature physical effects for fingerprint sensing.

AT77C101B has a linear shape, which captures a fingerprint image by sweeping the finger across the sensing area. After capturing several images, Atmel proprietary software can reconstruct a full 8-bit fingerprint image, if needed.

AT77C101B has a small surface combined with CMOS technology, and a Chip-On-Board or ceramic dual-in-line package assembly. These facts contribute to a low-cost device.

AT77C101B delivers a programmable number of images per second, while an integrated Analog to Digital Converter delivers a digital signal adapted to interfaces such as an EPP parallel port, USB microcontroller or directly to microprocessors. Thus, no frame grabber or glue interface is necessary to send the frames. These facts make AT77C101B an easy device to include in any system for identification or verification applications.

Table 1. Absolute Maximum Ratings⁽¹⁾

Parameter	Symbol	Comments	Value	Unit
Positive supply voltage	V_{CC}		GND to 6.5	V
Temperature stabilization power	TPP		GND to 6.5	V
Front plane	FPL		GND to V_{CC}	V
Digital input voltage	RST PCLK		GND to V_{CC}	V
Storage temperature	T_{stg}		-50 to +85	°C
Lead temperature (soldering, 10 seconds)	T_{leads}	Do not solder DIP: socket mandatory	Forbidden	°C

Note: 1. Absolute maximum ratings are limiting values, to be applied individually, while other parameters are within specified operating conditions. Long exposure to maximum ratings may affect device reliability.

Table 2. Recommended Conditions Of Use

Parameter	Symbol	Comments	Min	Typ	Max	Unit
Positive supply voltage	V_{CC}		3V	5V	5.5V	V
Front plane	FPL	Must be grounded	GND			V
Digital input voltage			CMOS levels			V
Digital output voltage			CMOS levels			V
Digital load	C_L				50	pF
Analog load	C_A R_A	Not connected				pF k Ω
Operating temperature range	T_{amb}	C grade D grade I grade	0°C to +70°C -20°C to +70°C -40°C to +85°C			°C
Maximum current on TPP	ITPP		0		100	mA

Table 3. Resistance

Parameter	Min Value	Standard Method
ESD		
On pins. HBM (Human Body Model) CMOS I/O	2 kV	MIL-STD-883- method 3015.7
On die surface (Zapgun) Air discharge	±16 kV	NF EN 6100-4-2
MECHANICAL ABRASION		
Number of cycles without lubricant multiply by a factor of 20 for correlation with a real finger	200 000	MIL E 12397B
CHEMICAL RESISTANCE		
Cleaning agent, acid, grease, alcohol, diluted acetone	4 hours	Internal method

Table 4. Specifications

Explanation Of Test Levels	
I	100% production tested at +25°C
II	100% production tested at +25°C, and sample tested at specified temperatures (AC testing done on sample)
III	Sample tested only
IV	Parameter is guaranteed by design and/or characterization testing
V	Parameter is a typical value only
VI	100% production tested at temperature extremes
D	100% probe tested on wafer at $T_{amb} = +25^{\circ}\text{C}$

Parameter	Test Level	Min	Typ	Max	Unit
Resolution	IV	50			μm
Size	IV	8x280			pixel
Yield: number of bad pixels	I			15	bad pixels
Equivalent resistance on TPP pin	I	23	30	47	Ω

Table 5. 5V Power Supply = +5V; $T_{amb} = 25^{\circ}\text{C}$; $F_{PCLK} = 1\text{ MHz}$; Duty cycle = 50%;
 C_{load} 120 pF on digital outputs, analog outputs disconnected unless otherwise specified.

Parameter	Symbol	Test level	Min	Typ	Max	Unit
Power Requirements						
Positive supply voltage	V_{CC}		4.5	5	5.5	V
Digital positive supply current on V_{CC} pin $C_{load} = 0$	I_{CC}	I IV		7 5	10 6	mA mA
Power dissipation on V_{CC} $C_{load} = 0$	P_{CC}	I IV		35 25	50 30	mW mW
Current on V_{CC} in NAP mode	I_{CCNAP}	I			10	μA
Analog Output						
Voltage range	V_{AVx}	I	0		2.9	V
Digital Inputs						
Logic compatibility			CMOS			
Logic "0" voltage	V_{IL}	I	0		1.2	V
Logic "1" voltage	V_{IH}	I	3.6		V_{CC}	V
Logic "0" current	I_{IL}	I	-10		0	μA
Logic "1" current	I_{IH}	I	0		10	μA
Digital Outputs						
Logic compatibility			CMOS			
Logic "0" voltage ⁽¹⁾	V_{OL}	I			1.5	V
Logic "1" voltage ⁽¹⁾	V_{OH}	I	3.5			V

Note: 1. With $I_{OL} = 1\text{ mA}$ and $I_{OH} = -1\text{ mA}$

Table 6. 3.3V Power supply = +3.3V; $T_{amb} = 25^{\circ}\text{C}$; $F_{PCLK} = 1\text{ MHz}$; Duty cycle = 50%; $C_{load} = 120\text{ pF}$ on digital outputs, analog outputs disconnected unless otherwise specified

Parameter	Symbol	Test Level	Min	Typ	Max	Unit
Power Requirements						
Positive supply voltage	V_{CC}		3.0	3.3	3.6	V
Digital positive supply current on V_{CC} pin $C_{load} = 0$	I_{CC}	I IV		6 5	10 6	mA mA
Power dissipation on V_{CC} $C_{load} = 0$	P_{CC}	I IV		20 17	33 20	mW mW
Current on V_{CC} in NAP mode	I_{CCNAP}	I			10	μA
Analog Output						
Voltage range	V_{AVx}	I	0		2.9	V
Digital Inputs						
Logic compatibility				CMOS		
Logic "0" voltage	V_{IL}	I	0		0.8	V
Logic "1" voltage	V_{IH}	I	2.3		V_{CC}	V
Logic "0" current	I_{IL}	I	-10		0	μA
Logic "1" current	I_{IH}	I	0		10	μA
Digital Outputs						
Logic compatibility				CMOS		
Logic "0" voltage ⁽¹⁾	V_{OL}	I			0.6	V
Logic "1" voltage ⁽¹⁾	V_{OH}	I	2.4			V

Note: 1. With $I_{OL} = 1\text{ mA}$ and $I_{OH} = -1\text{ mA}$

Table 7. Switching Performances. $T_{amb} = 25^{\circ}\text{C}$; $F_{PCLK} = 1\text{ MHz}$; Duty cycle = 50%
 C_{load} 120 pF on digital and analog outputs unless otherwise specified

Parameter	Symbol	Test Level	Min	Typ	Max	Unit
Clock frequency	f_{PCLK}	I	0.5	1	2	MHz
Clock pulse width (high)	t_{HCLK}	I	250			ns
Clock pulse width (low)	t_{LCLK}	I	250			ns
Clock setup time (high)/reset falling edge	t_{Setup}	I			0	ns
No data change	t_{NOOE}	IV	100			ns
Reset pulse width high	t_{HRST}	IV	50			ns

Table 8. 5.0V All Power Supplies = +5V

Parameter	Symbol	Test Level	Min	Typ	Max	Unit
Output delay from PCLK to ACKN rising edge	$t_{PLHACKN}$	I			90	ns
Output delay from PCLK to ACKN falling edge	$t_{PHLACKN}$	I			85	ns
Output delay from PCLK to Data output Dxi	t_{PDATA}	I			75	ns
Output delay from PCLK to Analog output Avx	$t_{PAVIDEO}$	I			260	ns
Output delay from OE to data high-Z	t_{DATAZ}	IV		25		ns
Output delay from OE to data output	t_{ZDATA}	IV		29		ns

Table 9. 3.3V All Power Supplies = +3.3V

Parameter	Symbol	Test Level	Min	Typ	Max	Unit
Output delay from PCLK to ACKN rising edge	$t_{PLHACKN}$	I			110	ns
Output delay from PCLK to ACKN falling edge	$t_{PHLACKN}$	I			100	ns
Output delay from PCLK to Data output Dxi	t_{PDATA}	I			90	ns
Output delay from PCLK to Analog output AVx	$t_{PAVIDEO}$	I			250	ns
Output delay from OE to data high-Z	t_{DATAZ}	IV		34		ns
Output delay from OE to data output	t_{ZDATA}	IV		47		ns

Figure 4. Reset

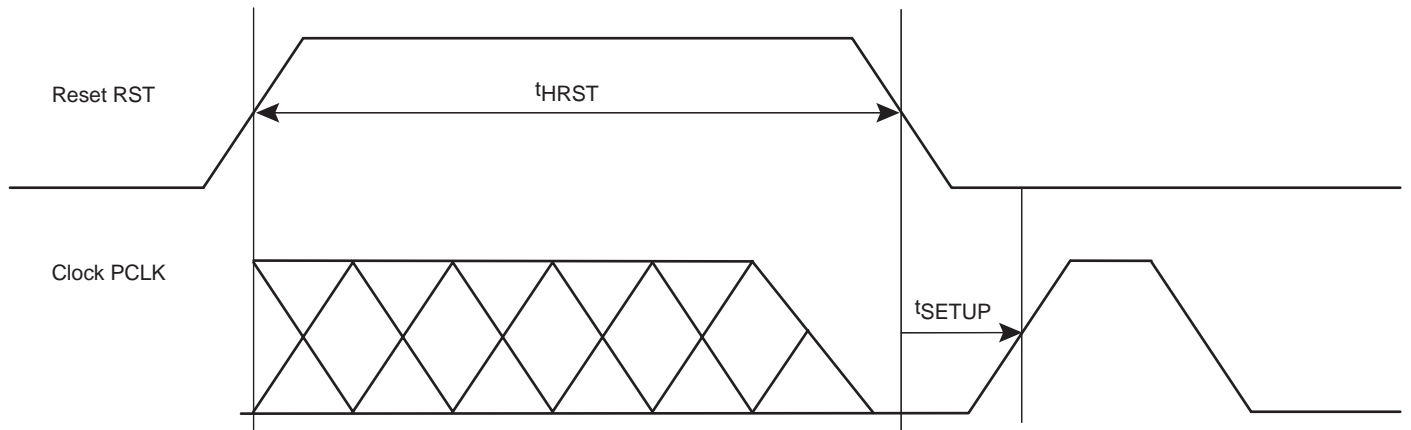

Figure 5. Read One Byte/Two Pixels

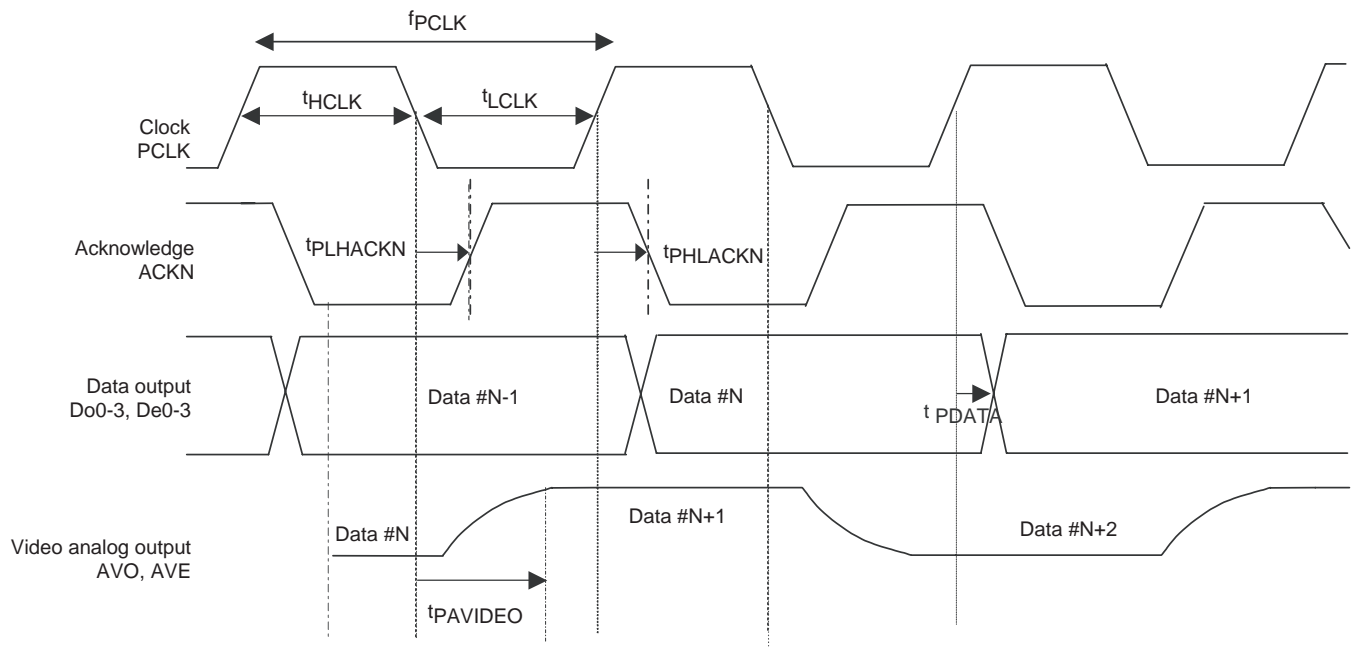

Figure 6. Output Enable

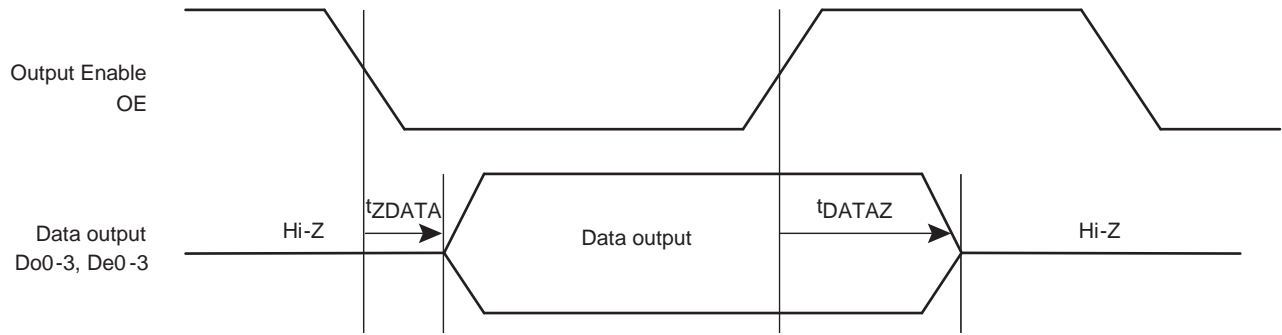
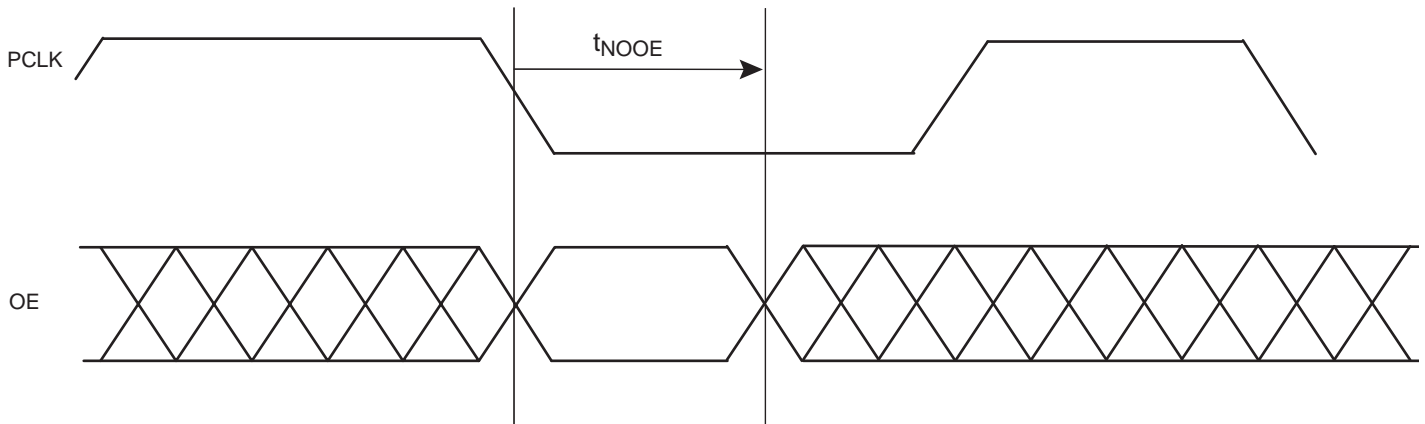
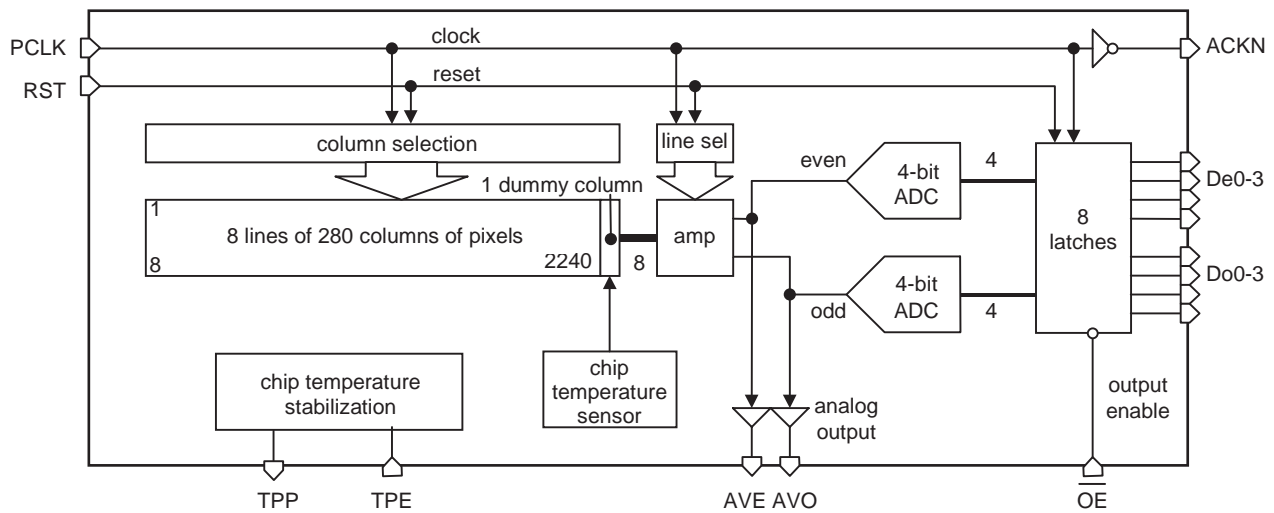

Figure 7. No Data Change



Note: OE must not change during T_{NOOE} after the PCLK falls. This is to ensure that the output drivers of the data are not driving current, to reduce the noise level on the power supply.

Figure 8. AT77C101B Block Diagram



Functional Description

The circuit is divided into two main sections: sensor and data conversion. One particular column among 280+1 is selected in the sensor array (1), then each pixel of the selected column sends its electrical information to amplifiers (2) (one per line), then two lines at a time are selected (odd and even) so that two particular pixels send their information to the input of two 4-bit Analog-to-Digital Converters (3), so 2 pixels can be read for each clock pulse (4).

Figure 9. Functional Description

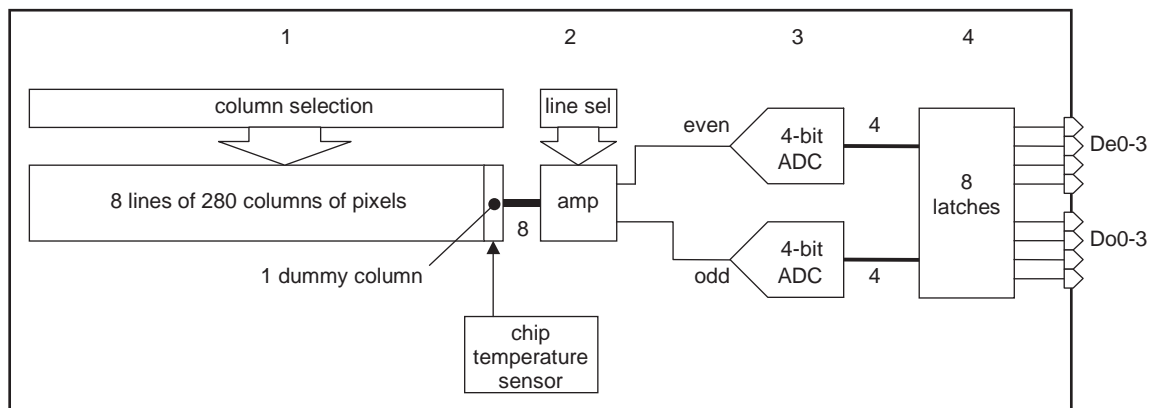

Sensor

Each pixel is a sensor in itself. The sensor detects a temperature differential between the beginning of acquisition and the reading of information: this is the integration time. The integration time begins with a reset of the pixel to a predefined initial state. Note that the integration time reset has nothing to do with the reset of the digital section.

Then, at a rate depending on the sensitivity of the pyroelectric layer, on the temperature variation between the reset and the end of the integration time, and on the duration of the integration time, electrical charges are generated at the pixel level.

Analog-to-Digital Converter/ Reconstructing an 8-bit Fingerprint Image

An Analog-to-Digital Converter (ADC) is used to convert the analog signal coming from the pixel into digital data that can be used by a processor.

As the data rate for parallel port and USB is in the range of 1 MB per second, and at least a rate of 500 frames per second is needed to reconstruct the image with a fair sweeping speed for the finger, two 4-bit ADCs have been used to output 2 pixels at a time on 1 byte.

Start Sequence

A reset is not necessary between each frame acquisition.

Start sequence must consist of:

1. Set the RST pin to high
2. Set the RST pin to low
3. Send 4 clock pulses (due to pipe-line)
4. Send clock pulses to skip the first frame

Note that the first frame never contains relevant information because the integration time is not correct.

Figure 10. Start Sequence

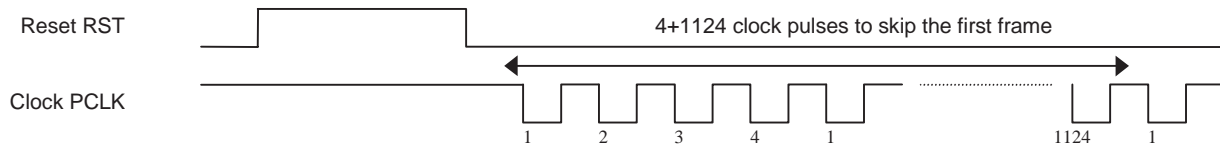

Reading the Frames

A frame consists of 280 true columns + 1 dummy column of 8 pixels. As two pixels are output at a time, a system must send $281 \times 4 = 1124$ clock pulses to read one frame.

Reset must be low when reading the frames.

Read One Byte/Output Enable

Clock is taken into account on the falling edge and data are output on the rising edge.

For each clock pulse, after the start sequence, a new byte is output on the Do0-3, De0-3 pins. This byte contains 2 pixels: 4-bit on Do0-3 (odd pixels), 4-bit on De0-3 (even pixels).

To output the data, the output enable (OE) pin must be low. When OE is high, the Do0-3 and De0-3 pins are in high-impedance state. This facilitates an easy connection to a microprocessor bus without additional circuitry since data output can be enabled using a chip select signal. Note that the AT77C101B is always sending data: there is no data exchange to perform using read/write mode.

Power Supply Noise

IMPORTANT: When a falling edge is applied on OE (i.e when the Output Enable becomes active), then some current is drained from the power supply to drive the 8 outputs, producing some noise. It is important to avoid such noise just after the falling edge of the clock PCLK, when the pixels information is evaluated: the timing diagram figure 5 and time T_{NOOE} defines the interval time where the power supply must be as quiet as possible.

Video Output

An analog signal is also available on pins AVE and AVO. Note that video output is available one clock pulse before the corresponding digital output (one clock pipe-line delay for the analog to digital conversion).

Pixel Order

After a reset, pixel number one is located on the upper left corner, looking at the chip with bond pads to the right. For each column of 8 pixels, pixels 1-3-5-7 are output on odd data Do0-3 pins, pixels 2-4-6-8 are output on even data De0-3 pins. Most significant bit is bit #3, least significant is bit #0.

Figure 11. Pixel Order

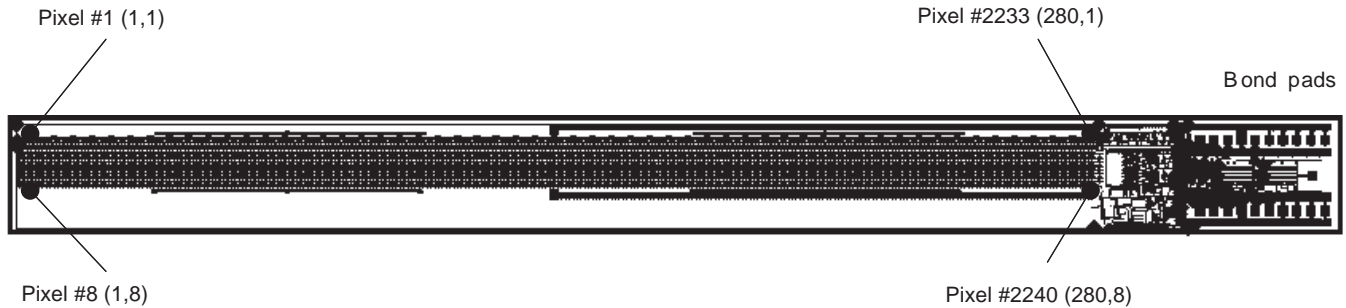

Synchronization: The Dummy Column

A dummy column has been added to the sensor to act as a specific pattern to detect the first pixel. So, 280 true columns + 1 dummy column are read for each frame.

The 4 bytes of the dummy column contain a fixed pattern on the two first bytes, and temperature information on the last two bytes.

Dummy Byte	Odd	Even
Dummy Byte 1 DB1:	111X	0000
Dummy Byte 2 DB2:	111X	0000
Dummy Byte 3 DB3:	rrrr	nnnn
Dummy Byte 4 DB4:	ttt	pppp

Note: x represents 0 or 1

The sequence 111X0000 111X0000 appears on every frame (exactly every 1124 clock pulses), so it is an easy pattern to recognize for synchronization purposes.

Thermometer

The dummy bytes DB3 and DB4 contain some internal and temperature information.

The even nibble nnnn in DB3 can be used to measure an increase (or decrease) of the chip temperature, using the difference between two measures of the same physical device. The following table gives values in Kelvin.

nnnn Decimal	nnnn Binary	Temperature differential with code 8 in Kelvin
15	1111	11.2
14	1110	8.4
13	1101	7
12	1100	5.6
11	1011	4.2
10	1010	2.8
9	1001	1.4
8	1000	0
7	0111	-1.4
6	0110	-2.8
5	0101	-4.2
4	0100	-5.6
3	0011	-7
2	0010	-8.4
1	0001	-11.2
0	0000	< -16.8

For code 0 and 15, the absolute value is a minimum (saturation).

When the image contrast becomes low because of a low temperature difference between the finger and the sensor, it is recommended to use the temperature stabilization circuitry to increase the temperature of two codes (i.e. from 8 to 10), to get at least an increase >1.4 Kelvin of the sensor. This enables to recover enough contrast to get a proper fingerprint for recognition purpose.

Integration Time and Clock Jitter

The AT77C101B is not very sensitive to clock jitter (clock variation). The most important requirement is a regular integration time that ensures the frame reading rate is also as regular as possible, in order to get consistent fingerprint slices.

If the integration time is not regular, contrast will vary from one frame to another.

Note that it is possible to introduce some waiting time between each set of 1124 clock pulses, but the overall time of one frame read must be regular. This waiting time is generally the time needed by the processor to perform some calculation over the frame (to detect the finger, for instance).

Figure 12. Read One Frame

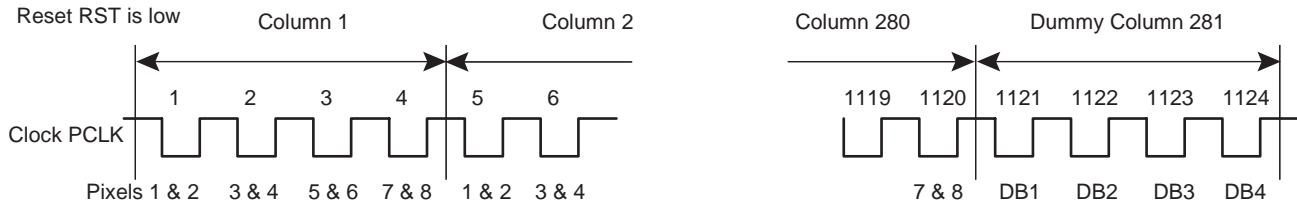
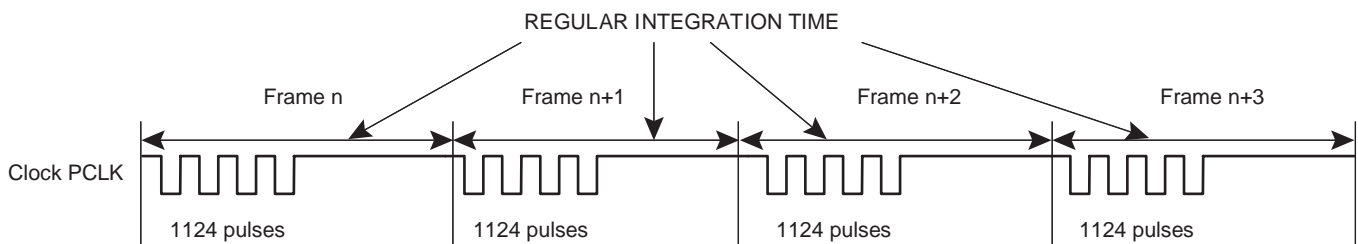

Figure 13. Regular Integration Time



Power Management

Nap Mode

Several strategies are possible to reduce power consumption when not in use.

The simplest and most efficient is to cut the power supply, using external means.

A nap mode is also implemented in the AT77C101B. To activate this nap mode, the user must:

1. Set the reset RST pin to high. Doing this, all analog sections of the device are internally powered down.
2. Set the clock PCLK pin to high (or low), thus stopping the entire digital section.
3. Set the TPE pin to low or disconnect TPP to stop the temperature stabilization feature.
4. Set Output Enable OE pin to high, so that output are forced in HiZ.

Figure 14. Nap Mode

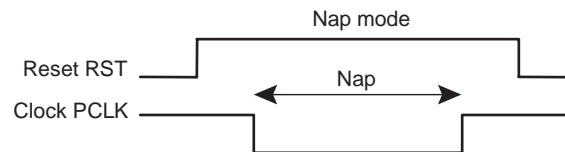

In Nap Mode, all internal transistors are in shut mode. Only leakage current is drained in power supply, generally less than the tested value.

Static Current Consumption

When the clock is stopped (set to 1) and the reset is low (set to 0), the analog sections of the device drain some current and the digital section does not consume current if the outputs are connected to a standard CMOS input (= no current is drained in the I/O). In this case the typical current value is 5 mA. This current does not depend on the voltage (i.e. it is almost the same from 3V to 5.5V).

Dynamic Current Consumption

When the clock is running, the digital sections are consuming current, and particularly the outputs if they are heavily loaded. In any case, it should be less than the testing machine (120 pF load on each I/O), 50 pF maximum is recommended.

Connected to a USB interface chip (see application note 26 related to the FCDEMO4 kit) at 5V, and running at about 1 MHz, the AT77C101B consumes less than 7 mA on V_{CC} pin.

Temperature Stabilization Power Consumption (TPP pin)

When the TPE pin is set to 1, current is drained via the TPP pin. The current is limited by the internal equivalent resistance given in table 4 and a possible external resistor.

Most of the time, TPE is set to 0 and no current is drained in TPP. When the image contrast becomes low because of a low temperature differential (less than one Kelvin), then it is recommended to set TPE to 1 during a short time so that the dissipated power in the chip elevates the temperature, enabling to recover contrast. The necessary time to increase the chip temperature of one Kelvin depends on the dissipated power, the thermal capacity of the silicon sensor and the thermal resistance between the sensor and the surroundings.

As a rule of thumb, dissipating 300 mW in the chip elevates the temperature of 1 Kelvin in one second. With the 30 Ω typical value, 300 mW is 3V applied on TPP.

Packaging: Mechanical Data

Figure 15. Product Reference: AT77C101B-CB010

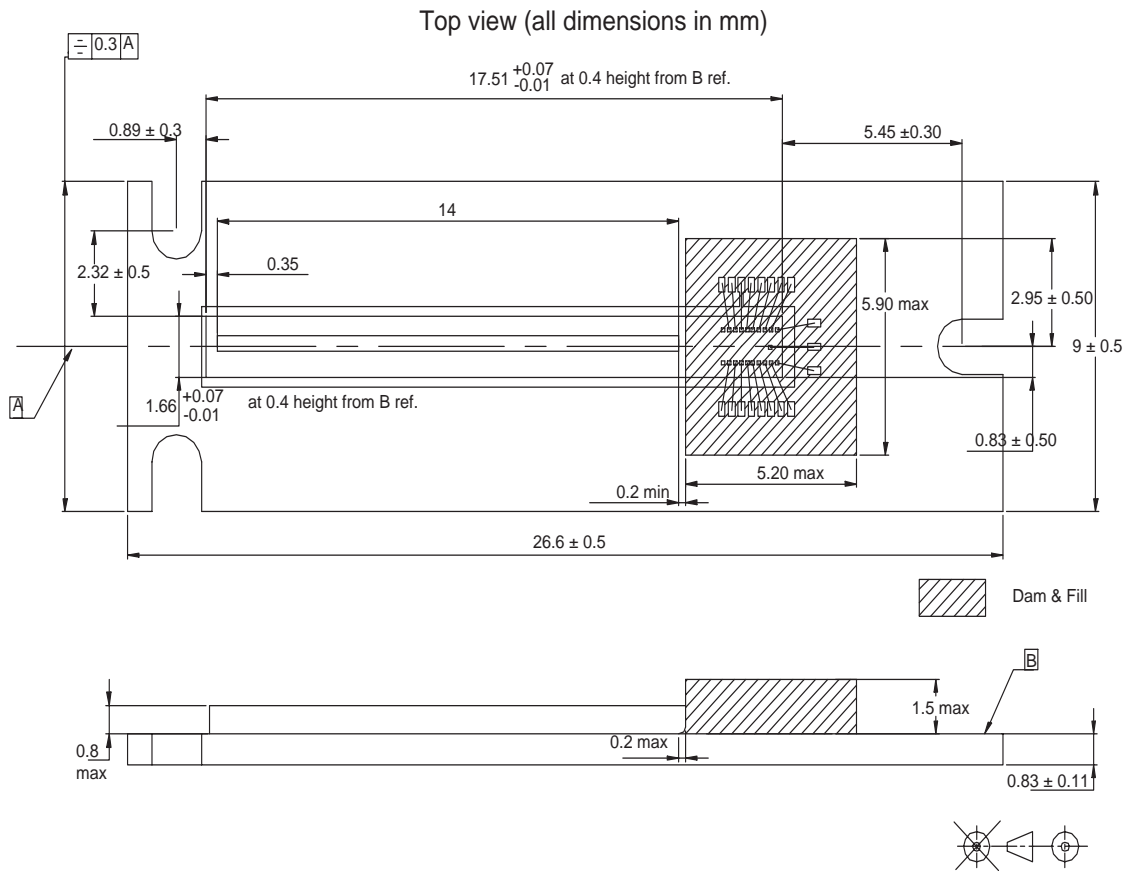

Figure 16. Product Reference: AT77C101B-CB010

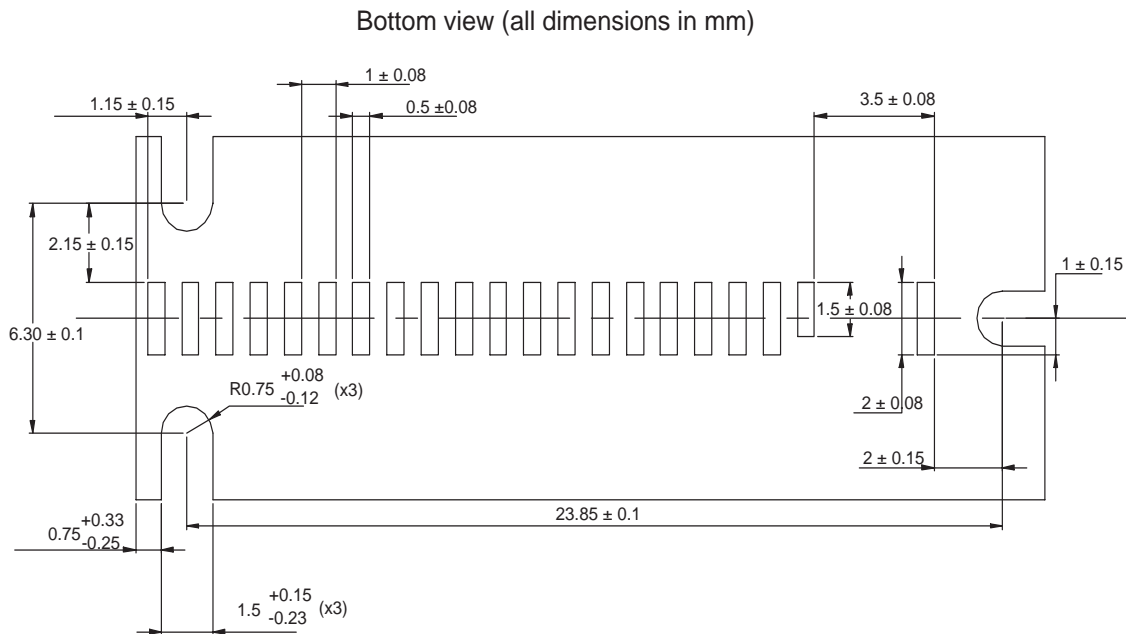

Figure 17. Product reference: AT77C101B-CB02⊖

All dimensions in mm

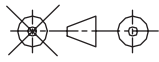
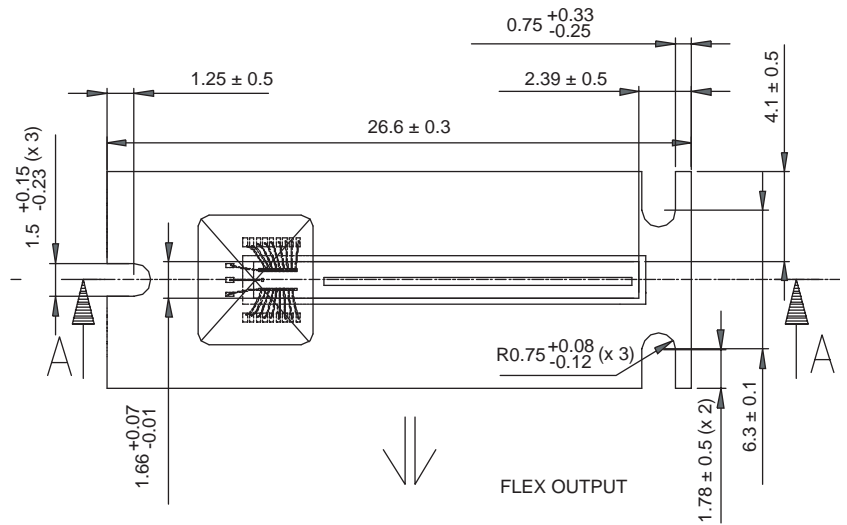
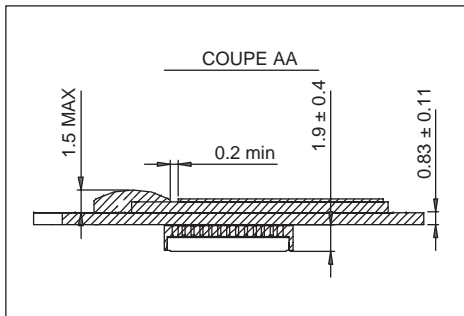
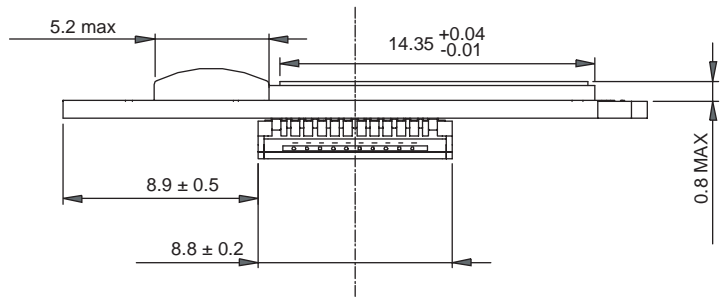
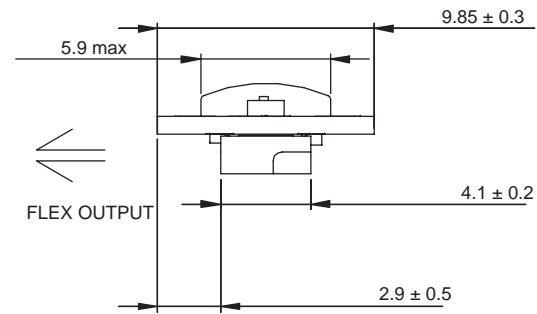
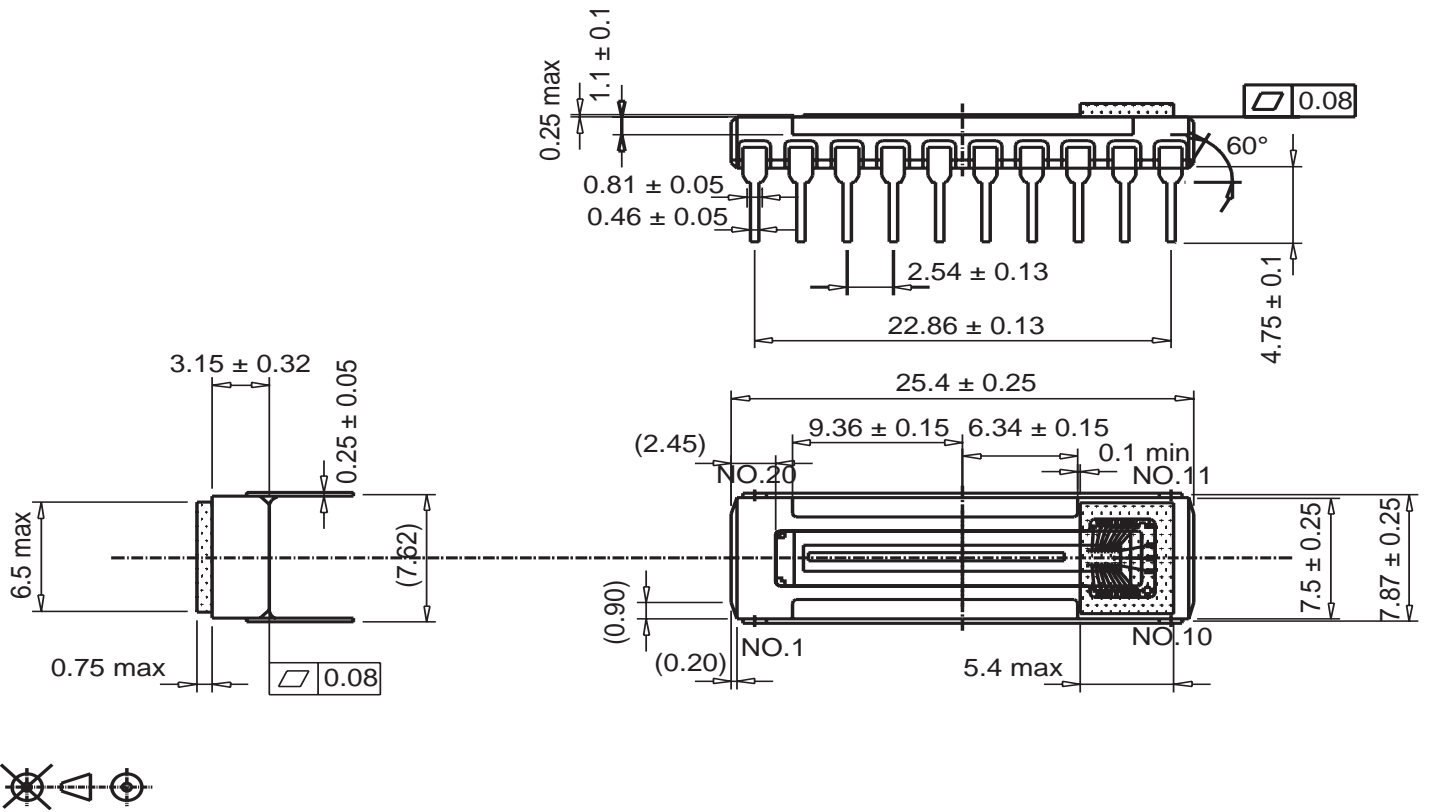

Figure 18. Product Reference: FCD4B14C0 (For Development Only)

DIL (all dimensions in mm)



Ordering Information

Package Device

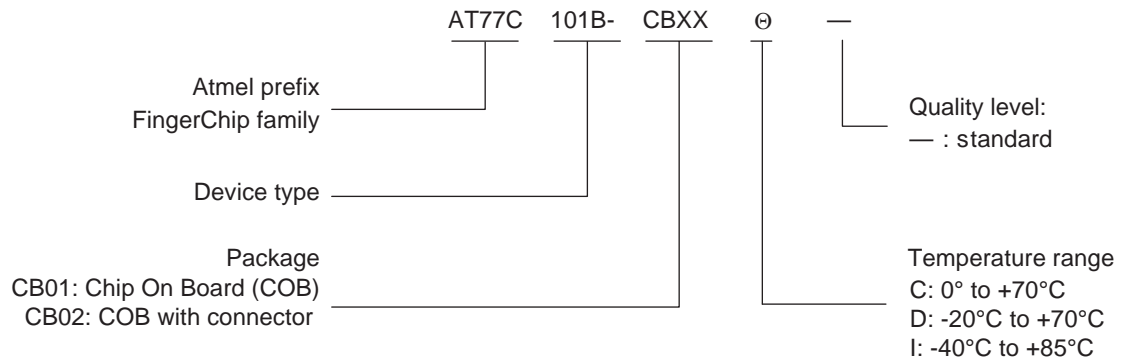

Note: AT77C101B part number replaces FCD4B14 and refers to same sensor.



Atmel Corporation

2325 Orchard Parkway
San Jose, CA 95131
Tel: 1(408) 441-0311
Fax: 1(408) 487-2600

Regional Headquarters

Europe

Atmel Sarl
Route des Arsenalux 41
Case Postale 80
CH-1705 Fribourg
Switzerland
Tel: (41) 26-426-5555
Fax: (41) 26-426-5500

Asia

Room 1219
Chinachem Golden Plaza
77 Mody Road Tsimshatsui
East Kowloon
Hong Kong
Tel: (852) 2721-9778
Fax: (852) 2722-1369

Japan

9F, Tonetsu Shinkawa Bldg.
1-24-8 Shinkawa
Chuo-ku, Tokyo 104-0033
Japan
Tel: (81) 3-3523-3551
Fax: (81) 3-3523-7581

Atmel Operations

Memory

2325 Orchard Parkway
San Jose, CA 95131
Tel: 1(408) 441-0311
Fax: 1(408) 436-4314

Microcontrollers

2325 Orchard Parkway
San Jose, CA 95131
Tel: 1(408) 441-0311
Fax: 1(408) 436-4314

La Chantrerie

BP 70602
44306 Nantes Cedex 3, France
Tel: (33) 2-40-18-18-18
Fax: (33) 2-40-18-19-60

ASIC/ASSP/Smart Cards

Zone Industrielle
13106 Rousset Cedex, France
Tel: (33) 4-42-53-60-00
Fax: (33) 4-42-53-60-01

1150 East Cheyenne Mtn. Blvd.
Colorado Springs, CO 80906
Tel: 1(719) 576-3300
Fax: 1(719) 540-1759

Scottish Enterprise Technology Park
Maxwell Building
East Kilbride G75 0QR, Scotland
Tel: (44) 1355-803-000
Fax: (44) 1355-242-743

RF/Automotive

Theresienstrasse 2
Postfach 3535
74025 Heilbronn, Germany
Tel: (49) 71-31-67-0
Fax: (49) 71-31-67-2340

1150 East Cheyenne Mtn. Blvd.
Colorado Springs, CO 80906
Tel: 1(719) 576-3300
Fax: 1(719) 540-1759

Biometrics/Imaging/Hi-Rel MPU/ High Speed Converters/RF Datacom

Avenue de Rochepleine
BP 123
38521 Saint-Egreve Cedex, France
Tel: (33) 4-76-58-30-00
Fax: (33) 4-76-58-34-80

e-mail

literature@atmel.com

Web Site

<http://www.atmel.com>

Disclaimer: Atmel Corporation makes no warranty for the use of its products, other than those expressly contained in the Company's standard warranty which is detailed in Atmel's Terms and Conditions located on the Company's web site. The Company assumes no responsibility for any errors which may appear in this document, reserves the right to change devices or specifications detailed herein at any time without notice, and does not make any commitment to update the information contained herein. No licenses to patents or other intellectual property of Atmel are granted by the Company in connection with the sale of Atmel products, expressly or by implication. Atmel's products are not authorized for use as critical components in life support devices or systems.

© Atmel Corporation 2003. All rights reserved. Atmel® and combinations thereof, are the registered trademarks of Atmel Corporation or its subsidiaries. FingerChip™ is the trademark of Atmel. Other terms and product names may be the trademarks of others.



Printed on recycled paper.